

Multi-Mixer type MM200

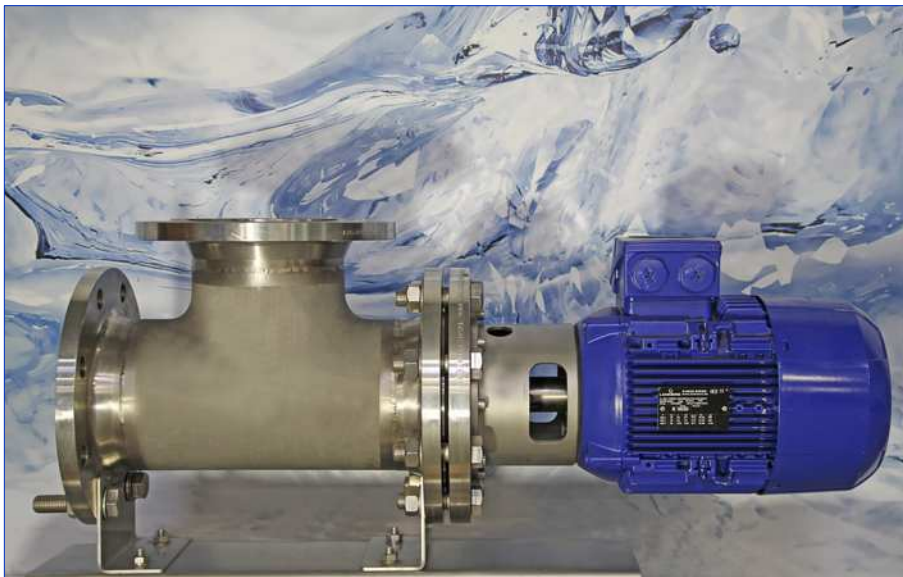

Features and advantages

- Compact and rugged design
- Few wear parts, low maintenance effort
- Stainless steel mixing chamber with flange connections
- Mixer housing and mixing shaft made of stainless steel
- Motor without forced ventilator (low-maintenance)
- Numerous options make it possible to adapt it in your process
- Lower polymer consumption from 5....25% possible
- Reduction of water consumption
- Higher content of TR in the filter cake up to 5 % possible
- Low costs because of high concentration of polymer
- Cost-saving because of smaller dosing pump and possibly elimination of subsequent dilution

Technical description and process

The dynamic multi-mixer MM200 optimizes the entry of flocculants in the mud and can be easily integrated in to existing sludge dewatering equipment and process control systems. It is suitable for a lot of different slurry and polymers.

The to conditioned sludge is exposed with polymer just before reaching of multi-mixer. The stock and process solution comes directly from the flocculant dissolving and dosing system.

Because of the innovative geometry of mixer blades is the structure of the sludge distabilized and at the same time with polymer wetted and mixed. The resulting slurry/polymer mixture is transported axially by the mixing housing and leaves the mixer again at an angle of 90°. The sludge flows then as far as possible free of turbulence in your thickening or dewatering system. During this time the desired floc structure can optimally develop.

Because of the sophisticated and innovative design of the multi-mixer results the robust construction and low maintenance. Ideally the multi-mixer is equipped with optional polymer supplying, a activation with frequency converter and the control for mass proportional polymer dosing.

Numerous options are available.



Schematic representation

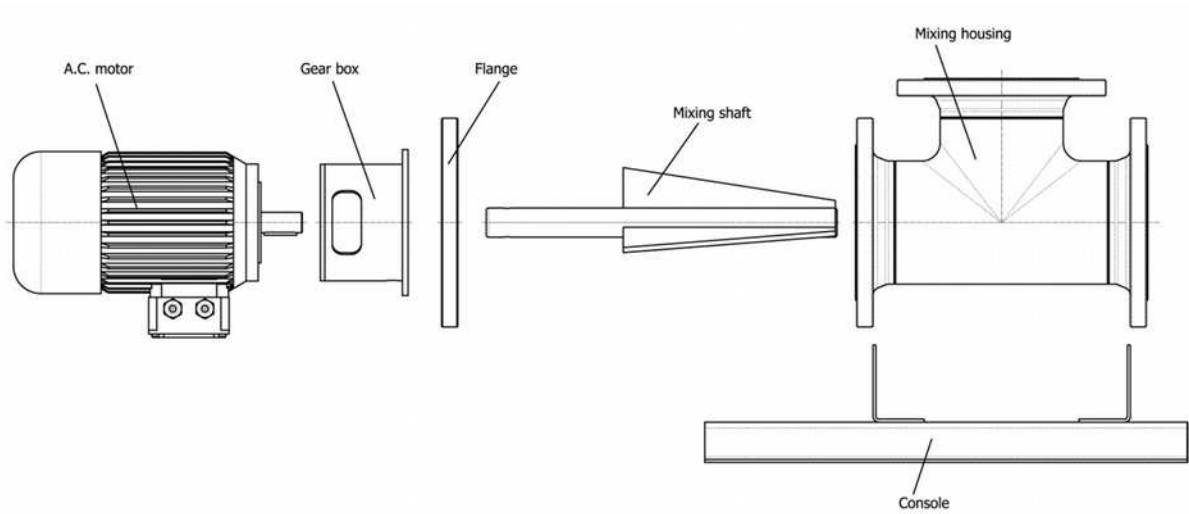

Dimensions of Multi-Mixer

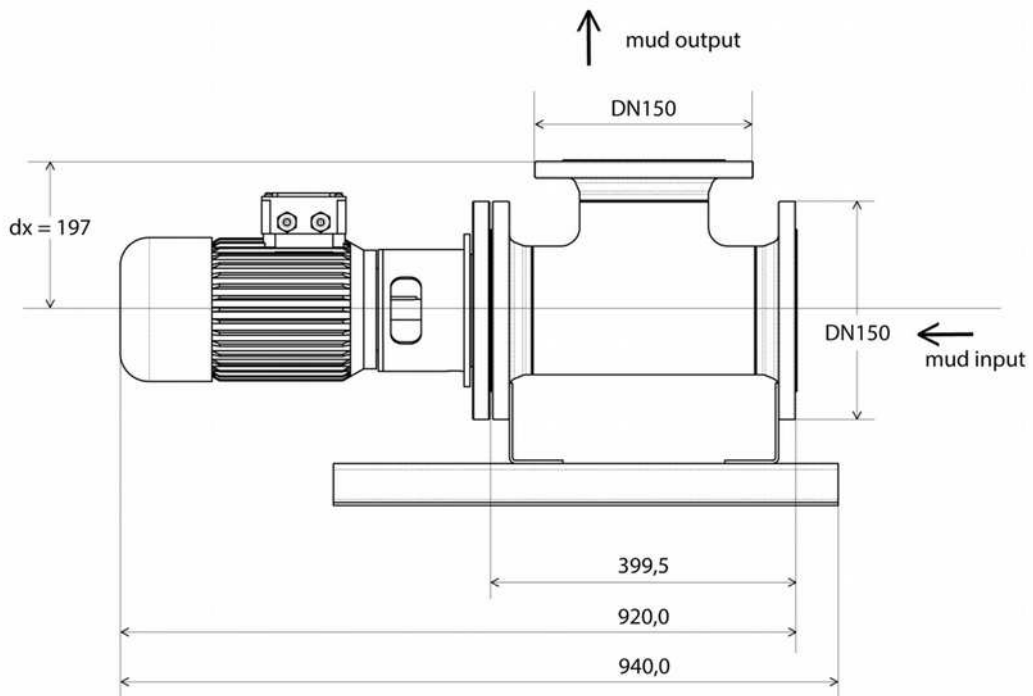

Options

For an optimal adaptation and integration into your process are numerous options available:

- Polymer feed with check valve
- Reduction of the ingress and egress flange DN150 to DN100
- Stainless steel machine frame for multi-mixer and the control cabinet



Application areas

The waterprocesstec Multi-Mixer is used in the treatment of municipal and industrial wastewater in sewage plants, the recycling of process and circuit water as well as the clarification of raw and surface water for the production of industrial and drinking water. Other applications are possible without doubts.

If you have any further questions, please do not hesitate to contact us.

Technical data

Electric motor

Design	3-phase squirrel cage motor
Protection class	IP55
Effect class	IE2 High Efficiency
Cooling	self cooling without filter
Temperature range	-20°C...+40°C
Material housing	gray iron
Colour	blue painted
Weight	31 Kg
Power	2,2KW
Voltage	230/400VAC, 500 VAC on request
Min. frequency for FU	20Hz

Mixer module

Design	compact
Material housing	stainless steel 1.4541
Material shaft	stainless steel 1.4541
Process connection	flange DN150 entry/exit (see also options)